



**ZIGMA-03 A**  
**FULL AUTOMATIC DOUBLE HEAD MITER SAW**  
**User's Manual**



CONTENTS	Page
<b>1. General Information</b>	<b>3</b>
1.1. Introduction	3
1.2. Distributor	3
<b>2. Machine's Description and Purpose of Use</b>	<b>3</b>
2.1. Machine's description	3
2.2. Technical features	5
2.3. Cutting diagram	6
<b>3. Operation of the Machine</b>	<b>7</b>
<b>4. Safety</b>	<b>7</b>
4.1. Safety Information	7
4.2. Accident Prevention	8
4.3. General Safety Information	8
<b>5. Control Panel</b>	<b>10</b>
<b>Pneumatic Cycle Diagram</b>	<b>13</b>
<b>Power and Control Cycle Diagram</b>	<b>14</b>
<b>Electric Cycle Diagram</b>	<b>15</b>



## **1. GENERAL INFORMATION**

### **1.1. INTRODUCTION**

*The user's manual given by the manufacturer contains necessary information about the machine parts. Each machine operator should read these instructions carefully, and the machine should be operated after fully understanding them.*

*Safe and efficient use of the machine for long term depends on understanding and following the instructions contained in this manual. The technical drawings and details contained in this manual constitute a guide for the operator.*

### **1.2. DISTRIBUTOR**

Atech Machine, Inc.  
7609-F Airpark Road – Gaithersburg, MD 20879 USA  
Phone: +1-301-556-9789 Toll Free: 1-866-80A-TECH Fax: +1-301-542-0140  
Website: [www.atechmachine.com](http://www.atechmachine.com) E-mail: [info@atechmachine.com](mailto:info@atechmachine.com)

*In case of any technical problem please contact your nearest ATECH dealer, or ATECH head office through the above mentioned phone, fax or e-mail address.*

*Technical labels with the model description of the machine are fixed onto the front side of each machine.*

*The machine's serial number and manufacturing year are stipulated on the technical label.*

## **2. MACHINE'S DESCRIPTION AND PURPOSE OF USE**

### **2.1. MACHINE'S DESCRIPTION**

*Full automatic double head miter saw with circular saw blades for serial cutting of PVC and/or aluminum profiles in desired angles.*

- *Equipped with 450 mm (18") circular saw blades*
- *The saw blade speed and angles are adjustable*
- *Intermediate angles are adjusted manually*
- *Pneumatic twin clamping*
- *Equipped with 3 m (9 ft) movable conveyor*
- *Spray mist lubrication system for cutting of aluminum*
- *Saw blade shaft diameter 32 mm (1.3")*
- *Left head is fixed, right head is movable and positioned automatically*
- *Cutting precision is +/- 0.1 mm*
- *Minimum cutting length is 460 mm (18")*
- *Maximum cutting length is 4000 mm (157")*



- As the saw heads are closed towards inside there is no need to calculate width at 45° and 90°
- PLC controlled





### **Control Panel**

- Touch screen
- Main menu includes start page, manual control page, automatic control page, coefficient page, shortcut page, cutting list page
- Motor is start-stop button controlled
- Clamps and guards are button controlled
- Angles are button controlled
- Cutting is start button controlled
- Double hand operation for operator's safety
- Cutting program with 300 inputs
- At each step the length, angles and quantities are entered
- At automatic operation the cutting list is executed by order
- Cutting list values can be transferred from a PC automatically
- Cutting list values can be entered manually

Please include the below mentioned data in all your correspondence regarding the machine with the manufacturer and/or your ATECH dealer.

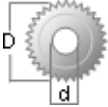
- \*Machine model
- \*Machine's serial number
- \*Voltage and frequency
- \*Name of dealer where machine was purchased
- \*Date of purchase
- \*Description of the machine fault
- \*Average daily operation period

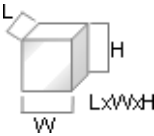
## 2.2. TECHNICAL FEATURES

Technical Features							
<b>ZIGMA-03A</b>	6 HP (4.5 kW) 220V (400V) 50/60Hz	d=30-32 mm (1.2"/1.3") D=450 mm (18")	2800 rpm	90-120 psi	1 CFM	490x120x135 (193"x48"x53")	1280 kg (2816 lbs)

### 2.3. CUTTING DIAGRAM

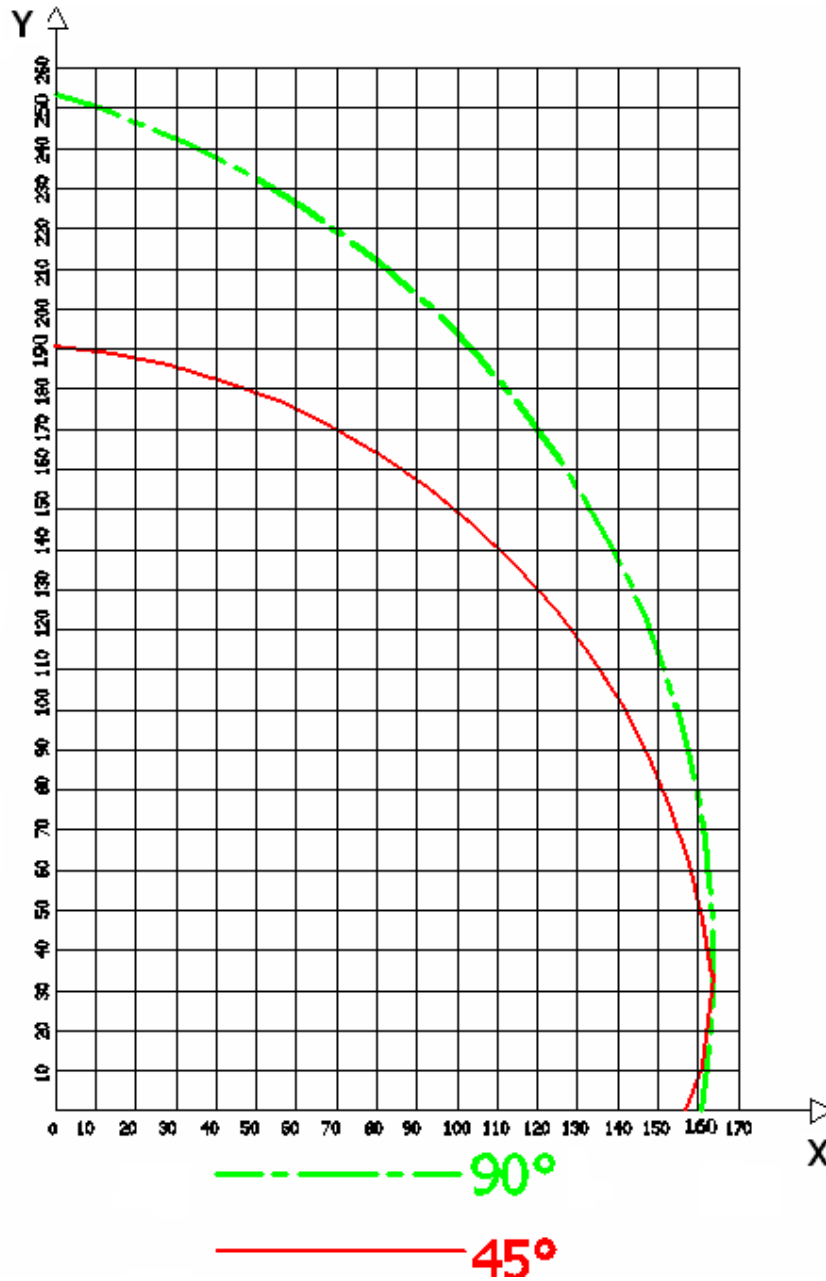



### 3. OPERATION OF THE MACHINE

Check that the air pressure reading on the manometer is 6 Bar (90 psi).

Switch the main switch on the machine to position "1" and position the movable head (see instructions for using the touch screen).

Ensure that the saw blades rotate in the correct direction by pushing the "LEFT BLADE" and "RIGHT BLADE" buttons.

Place the profile onto the machine, press the "CLAMP" button on the control panel.

After ensuring that the profile has been clamped and the protection covers closed, press the two "START" buttons on the control panel simultaneously and make so a single cut at the start point. When the cutting process is finished, clamps release and protection covers open automatically.

Measure the cut profile and compare it with the saw blade distance value on the coefficient page of the touch screen (see coefficient page of the touch screen instructions).

Place the profile onto the machine table.

Enter the cutting measurement and angle values via touch screen on the control panel, example: 2000 mm (79"), 90°, 90° (see shortcut page of the touch screen instructions).

After the machine has been positioned at the entered measurement and angles, press the "CLAMP" button and ensure that profile is clamped properly and the protection covers are closed.

If the machine is in ready to cut position, start the cutting process by pressing the "START" button.

After making the cut, compare the length measurement of the cut profile, if the measurement is wrong then see coefficient page of the touch screen instructions.

To make automated cuts please check the appropriate page in this manual.

### 4. SAFETY

#### 4.1. SAFETY INFORMATION

The symbols shown hereunder are necessary to be read with special attention. Not reading or observing of them may cause damage to the equipment or personal injury.

**IMPORTANT**

The **IMPORTANT** symbol above is one telling to apply special care and to be careful at carrying out the specified operation.

**CAUTION !**

The **CAUTION!** Symbol above warns you against specific dangers, and requires to read the text. Not observing may cause damage to the equipment.



### **DANGER WARNING**

The above symbol **DANGER WARNING**, warns you against specific dangers, and you have definitely to read them. Negligence may cause damage to the equipment and bodily injury.

Read the user's manual carefully before using the machine or carrying out maintenance works.



## **4.2. ACCIDENT PREVENTION**

**4.2.1.** Our machines are manufactured in accordance with EN 60204-1 and EN 292-2 CE safety directives, which cover national and international safety directives.

**4.2.2.** It is the task of the employer to warn his staff against accident risks, to train them on prevention of accidents, to provide for necessary safety equipment and devices for the operator's safety.

**4.2.3.** Before starting to work with the machine, the operator should check the features of the machine, learn all details of the machine's operation.

**4.2.4.** Machine should be operated only by staff members, who have read and understood the contents of this manual.

**4.2.5.** All directives, recommendations and general safety rules contained in this manual have to be observed fully. The machine cannot be operated in any way for purposes other than those described herein. Otherwise, the manufacturer shall not be deemed responsible for any damages or injuries. And such circumstances would lead to the termination of the warranty.

## **4.3. GENERAL SAFETY INFORMATION**



**4.3.1.** The power cable should be led in such a way that nobody can step on it or nothing can be placed on it. Special care has to be taken regarding the inlet and outlet sockets.



**4.3.2.** If the power cable should be damaged during operation, don't touch and unplug it. Never use damaged power cables.

**4.3.3.** Don't overload machines for drilling and cutting. Your machine will operate more safely with power supply in accordance with the stipulated values.



**4.3.4.** Don't place your hands between parts in motion.



**4.3.5.** Use protective eye glasses and ear plugs. Don't wear oversize clothes and jewels. These can be caught by moving parts.



**4.3.6.** Keep your working place always clean, dry and tidy for accident prevention and safe operation.

**4.3.7.** Use correct illumination for the safety of the operator. (ISO 8995-89 The Lighting of Indoor Work Systems)

**4.3.8.** Don't leave anything on the machine.

**4.3.9.** Don't use any materials other than those recommended by the manufacturer for cutting operations on the machine.

**4.3.10.** Ensure that the work piece is clamped appropriately by the machine's clamp or vice.



**4.3.11.** Ensure safe working position, always keep your balance.

**4.3.12.** Keep your machine always clean for safe operation. Follow the instructions at maintenance and replacement of accessories. Check the plug and cable regularly. If damaged, let it replace by a qualified electrician. Keep handles and grips free of any oil and grease.

**4.3.13.** Unplug first, before conducting and maintenance works.

**4.3.14.** Ensure that any keys or adjustment tools have been removed before operating the machine.

**4.3.15.** *If you are required to operate the machine outside, use only appropriate extension cables.*

**4.3.16.** *Repairs should be carried out by qualified technicians only. Otherwise, accidents may occur.*

**4.3.17.** *Before starting a new operation, check the appropriate function of protective devices and tools, ensure that they work properly. All conditions have to be fulfilled in order to ensure proper operation of your machine. Damaged protective parts and equipment have to be replaced or repaired properly (by the manufacturer or dealer).*

**4.3.18.** *Don't use machines with improper functioning buttons and switches.*

**4.3.19.** *Don't keep flammable, combustive liquids and materials next to the machine and electric connections.*

## 5. CONTROL PANEL

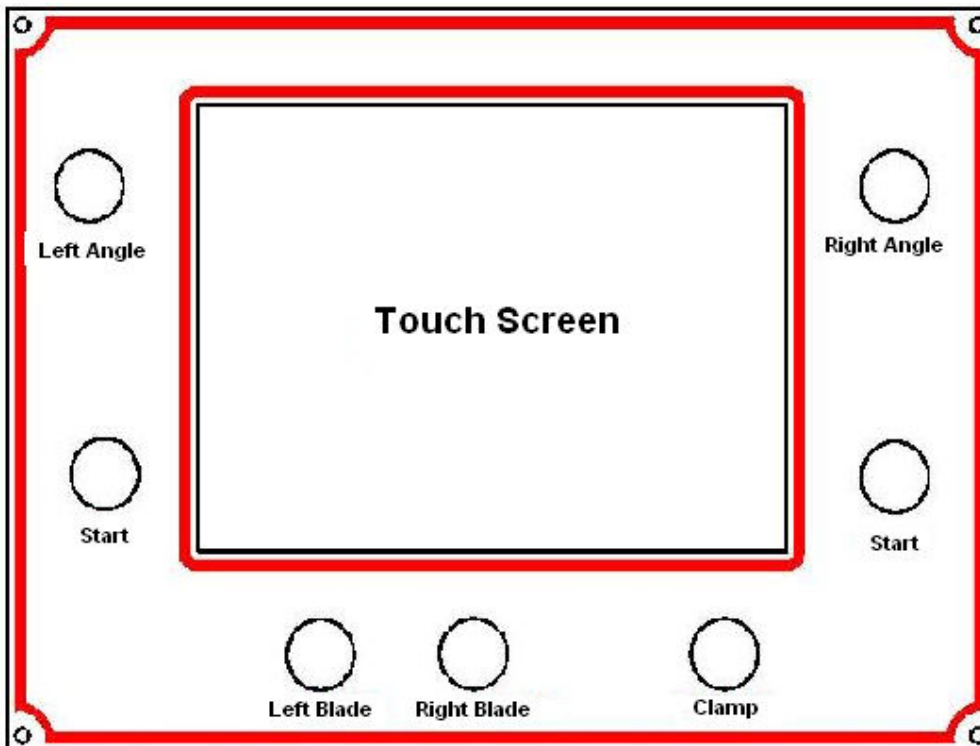

**LEFT ANGLE:** *It is used to adjust the left saw blade to 90° or 45° at manual operation.*



**RIGHT ANGLE:** *It is used to adjust the right saw blade to 90° or 45° at manual operation.*

**START:** *There two Start buttons on the control panel. It is necessary to press both simultaneously in order to make cuts.*

**LEFT BLADE:** *It is used to start and stop the left saw blade.*

**RIGHT BLADE:** *It is used to start and stop the right saw blade.*

**CLAMP:** *It is used to operate the clamps and to close the protection covers.*

## **5. Touch Screen and Control Panel Instructions**

### **Main Screen**

*The screen, which comes up first when the panel is activated.*

*Here you can select the Menu screen, Origin screen, Shortcut screen, Manual screen, Coefficient screen.*

### **Menu Screen**

*This is the screen, where you enter the values for automated cutting. It includes 300 cutting options. At each option you enter the values for length, left angle, right angle and total number of pieces to cut. The menu values can be entered manually or via external PC. In order to enter the values via PC, you have to chose the PC mode at the manual/PC selection.*

### **Origin Screen**

*It is the screen, which you have to use when the machine is switched on the first time. When the "Find Origin" button is pressed and released, the movable head automatically searches for the origin point. When the origin point is found, lights at the right and left bottom corners of the machine illuminate. If a deviation in measurement occurs during the operation, it is necessary to repeat the "Find Origin" step and to check the measurements again. If the movable head is in far distance to the fixed head during the "Find Origin" step, the moving speed of the movable head can be increased by using the transparent button located mid-left of the screen. It is very important to avoid that the movable head collides with the fixed head during the "Find Origin" step. Therefore, when you use the transparent button to speed up the movement of the movable head, you have to release it once you approach the fixed head.*

### **Automatic Screen**

*It the page, where you program the machine for automated cutting. When you first enter this screen, you can chose the Menu step. The machine moves automatically to the next steps. Example: If you chose step 3, the machine executes the steps 3, 4, 5... Automatically. Automatic operation is started and terminated through the manual/automatic button located at the bottom right corner on the screen. The values entered in the Menu screen are carried out by the machine step by step. The number of cut pieces are count automatically and the machine moves to the next step once the entered quantity value has been reached. The machine moves to the values of the new step automatically, angles are operated automatically, once the Automatic screen is left the machine leaves the Automatic operation mode.*



### **Shortcut Screen**

*It is a page designed to make manual use of the machine easier. The cutting measurement (mm/inch) is entered through the keyboard on the screen. This value is confirmed to the machine by pressing the Enter button. By pressing the "Go To Length" button, the movable head is positioned at the desired length.*

### **Manual Screen**

*It is the page, where the operations of the shortcut screen are carried out. Furthermore, the head can be moved to right, left, slow and quick via direction buttons. It can be seen whether the right and left angles are 90° or 45°. It can also be seen if the saw blades are in forward or backward position. There is a waiting time of 5 seconds when the machine has been started first time. This can be followed up on this screen.*

### **Coefficient Screen**

*It is page, where the true values of the measurements are entered and checked. It is compulsory that the page is used by authorized service personnel or under their control. The saw blade distance value at the origin point and the multiplication coefficient for finding the length are entered in this screen. The measurement of a profile cut at the origin point has to correspond with the distance value between the saw blades.*

# PNEUMATIC CYCLE DIAGRAM

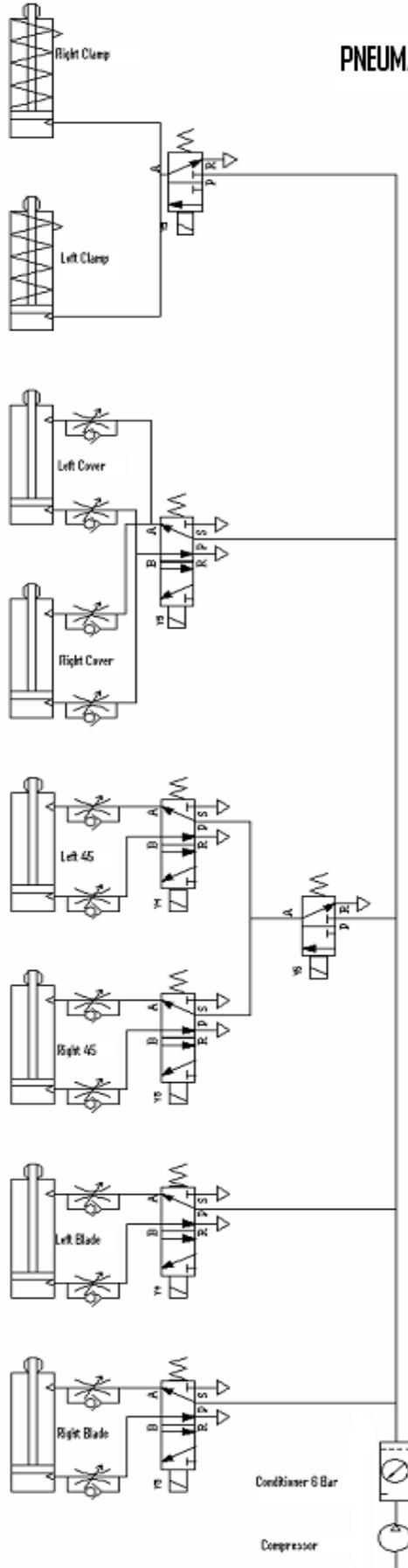

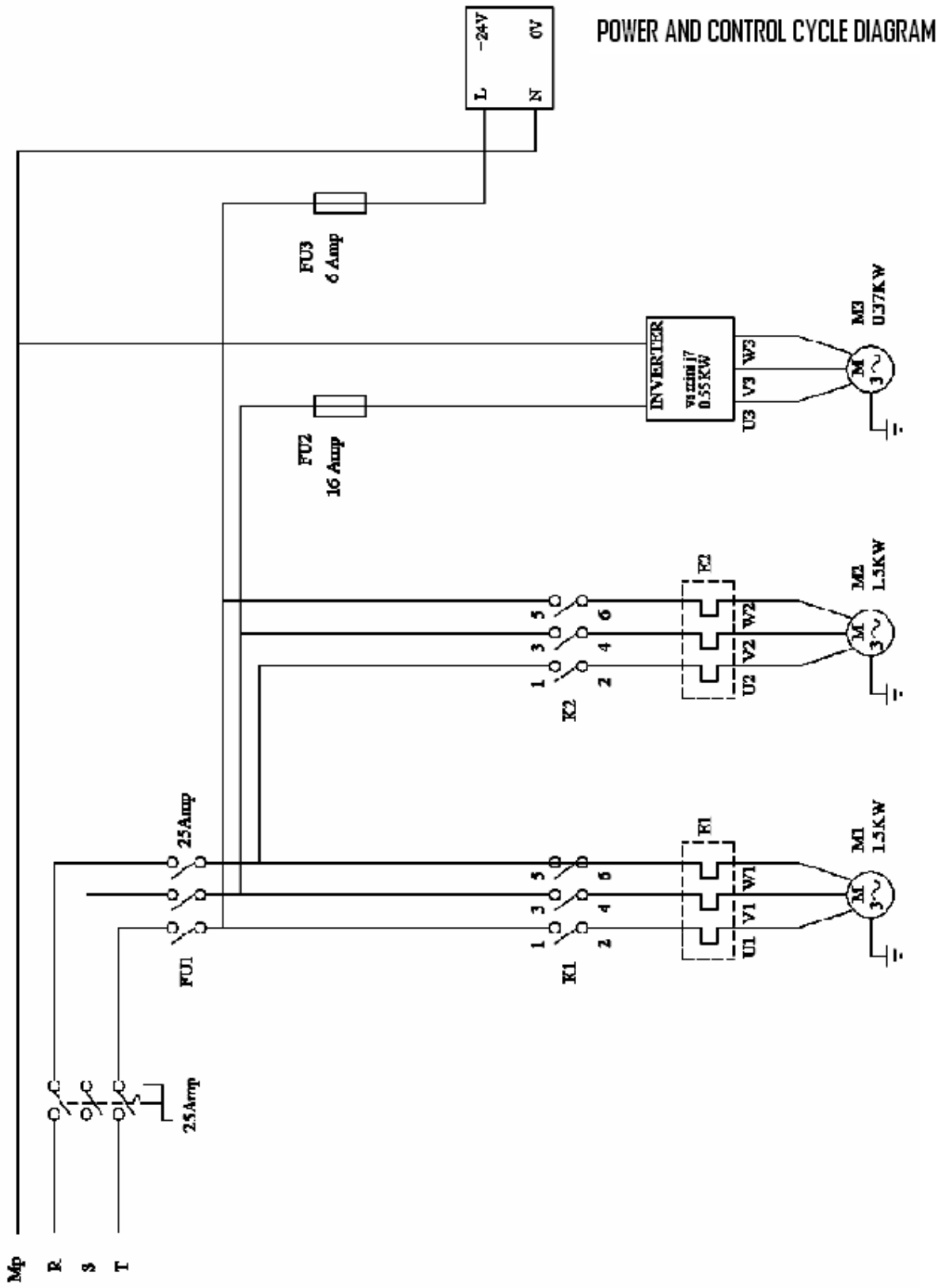

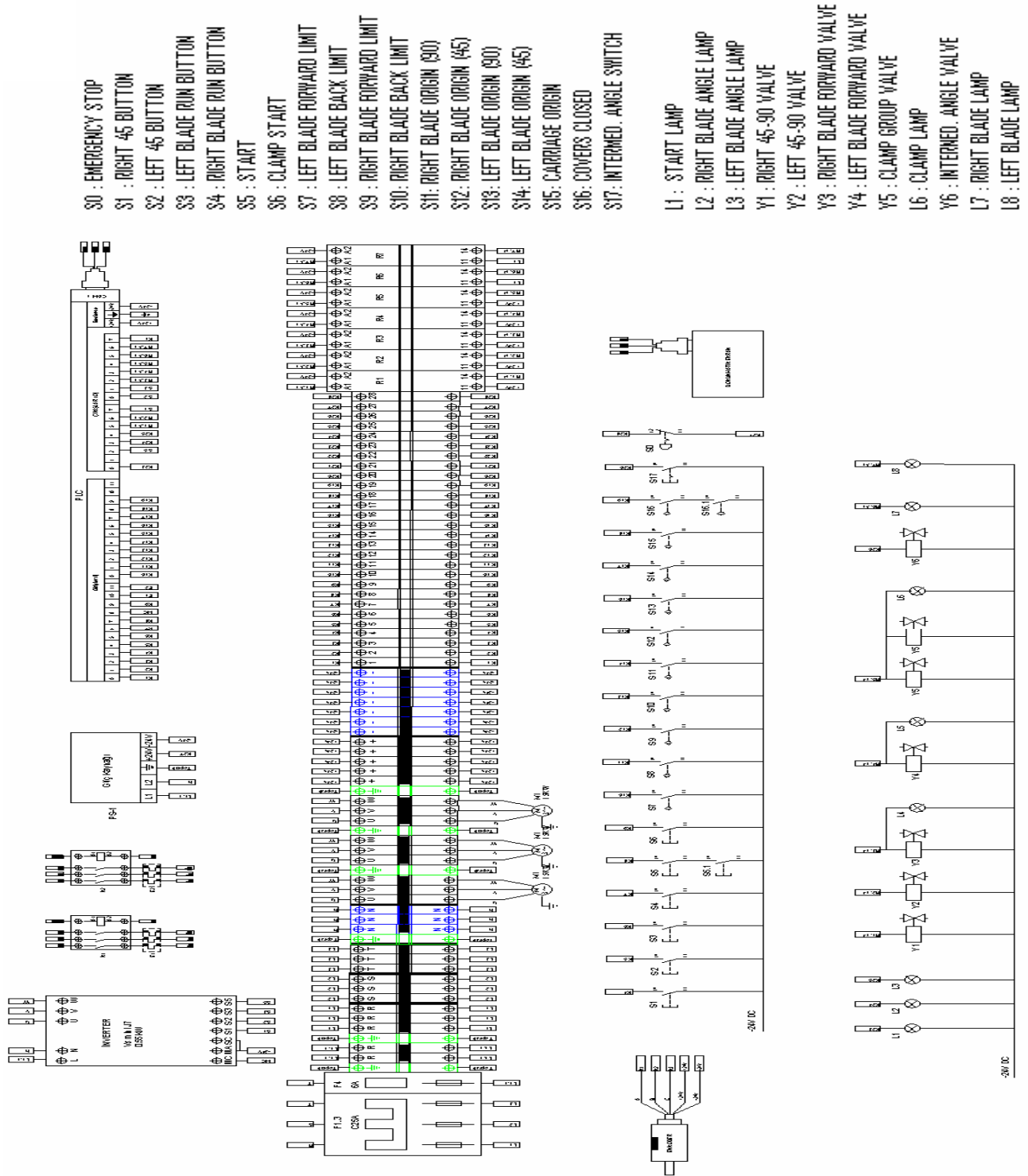

### ELECTRIC CYCLE DIAGRAM