



## **DOLPHIN-02 A**

# **AUTOMATIC WATER SLOT MILLING MACHINE**

## **USER'S MANUAL**

<b>CONTENTS</b>	<b>Page</b>
<b>1. General Information</b>	<b>3</b>
1.1. Introduction	3
1.2. Manufacturer	3
<b>2. Machine's Description and Purpose of Use</b>	<b>3</b>
2.1. Machine's description	3
2.2. Technical features	5
2.3. Overall dimensions	6
2.4. Part lists and technical drawings	7
<b>3. Safety</b>	<b>8</b>
3.1. Safety information	8
3.2. Accident prevention	8
3.3. General safety information	9
<b>4. Transport of the Machine</b>	<b>10</b>
<b>5. Installation of the Machine and Electric Connection</b>	<b>11</b>
<b>6. Machine Safety Information</b>	<b>11</b>
<b>7. Operation</b>	<b>14</b>
7.1. Changing the router bit	14
7.2. Adjusting the machine's air pressure	15
<b>8. Maintenance</b>	<b>15</b>
8.1. Periodic checks	15
8.2. Maintenance at the end of working day	16
<b>9. Troubleshooting Guide</b>	<b>16</b>
<b>10. Electric / Pneumatic Components</b>	<b>17</b>
10.1. Electric Components	17
10.2. Pneumatic Components	17



## **1. GENERAL INFORMATION**

### **1.1. INTRODUCTION**

*The user's manual given by the manufacturer contains necessary information about the machine parts. Each machine operator should read these instructions carefully, and the machine should be operated after fully understanding them.*

*Safe and efficient use of the machine for long term depends on understanding and following the instructions contained in this manual. The technical drawings and details contained in this manual constitute a guide for the operator.*

### **1.2. DISTRIBUTOR**

*ATech Machine, Inc.  
19322 Woodfield Road – Gaithersburg, MD 20879 USA  
Phone: +1-301-355-5727 Fax: +1-301-560-6627  
Website: [www.atechmachinery.com](http://www.atechmachinery.com) E-mail: [info@atechmachinery.com](mailto:info@atechmachinery.com)*

*In case of any technical problem please contact your nearest ATECH dealer, or ATECH head office through the above mentioned phone fax or e-mail address.*

*Technical labels with the model description of the machine are fixed onto the front side of each machine.*

*The machine's serial number and manufacturing year are stipulated on the technical label.*

## **2. MACHINE'S DESCRIPTION AND TECHNICAL FEATURES**

### **2.1. MACHINE'S DESCRIPTION**

*This machine has been designed for milling of water discharge slots onto PVC profiles on two or three axes, in different angles and heights.*

- It automatically adjusts axis deviations.*
- Automatic operation via single button.*
- Motor selection via buttons. Model DOLPHIN-02 A is equipped with 3 motors.*

*Please mention the below mentioned data in all your correspondence regarding the machine with the manufacturer and/or your ATECH dealer.*



*\*Machine model*

*\*Machine's serial number*

*\*Voltage and frequency*

*\*Name of dealer where machine was purchased*





*\*Date of purchase*





*\*Description of the machine fault*

*\*Average daily operation period*



## 2.2 TECHNICAL FEATURES

Technical Features (American)					
DOLPHIN-02 A With 2 Drills	600W X 2 120V 60Hz	27000 rpm	90-120 psi	1 CFM 20x20x54"	139 lb
DOLPHIN-02 A With 3 Drills	600W X 3 120V 60Hz	27000 rpm	90-120 psi	1 CFM 20x20x54"	145 lb

Technical Features (Metric)					
DOLPHIN-02 A With 2 Drills	600W X 2 230V 50Hz	27000 rpm	6-8 Bar	27 l/min 50x51x138 cm	63 kg
DOLPHIN-02 A With 3 Drills	600W X 3 230V 50Hz	27000 r.p.m	6-8 Bar	27 l/min 50x51x138 cm	66 kg



### 2.3 OVERALL DIMENSIONS

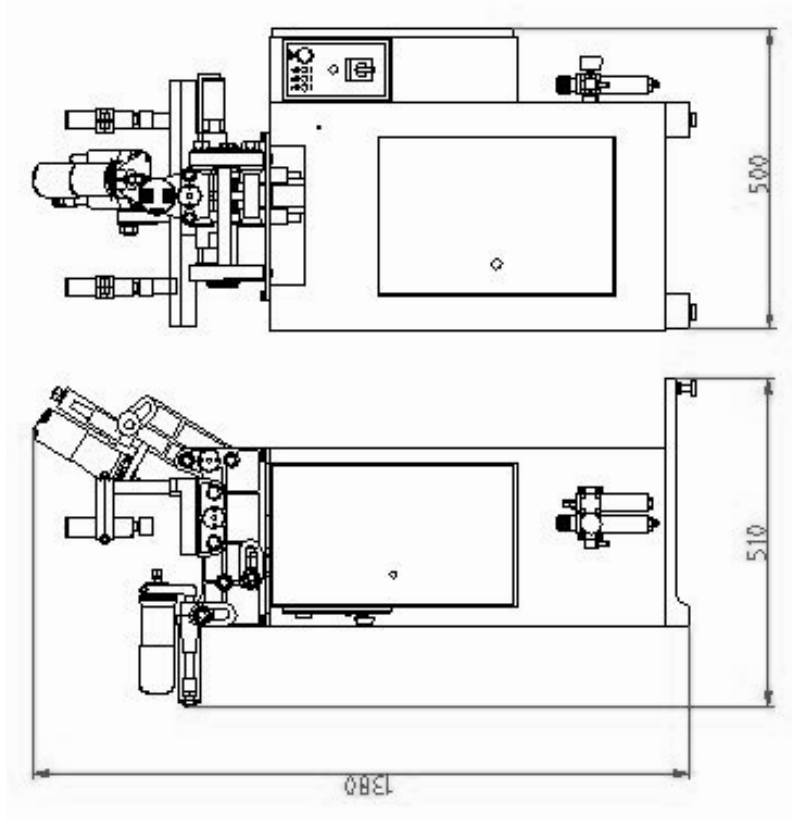

## 2.4 PART LISTS AND TECHNICAL DRAWINGS

NO	STOCK CODE	PART NAME	QTY
9	111-149	MOTOR MOVEMENT BAD	3
10	111-152	TABLE HOUSING	2
11	111-150	TABLE	1
12	143-019	AXIS MOVEMENT SHAFT	4
13	141-141	FOOT ADJUSTMENT BOLT	2
14	241-009	CONDITIONER	1
15	145-032	UPPER CONNECTION ROD	2
17	211-017	FRAME	1
18	111-147	FRAME BASE	2
21	111-151	LATERAL CONNECTION	2
23	163-003	MOTOR	3
26	143-021	1.MOTOR HOUSING SHAFT (LEFT)	1
28	143-023	2.MOTOR HOUSING SHAFT (RIGHT)	1
33	141-221	CLAMP COLUMN SHAFT	2
35	550-003	PNEUMATIC CLAMP	2
40	550-023	AXIS POSITIONING PISTON	2
42	550-024	2.MOTOR PISTON	2
43	143-017	2.MOTOR PISTON SHAFT	2
48	211-017	PANEL	1
49	141-219	MOTOR ADJUSTMENT BOLT	2

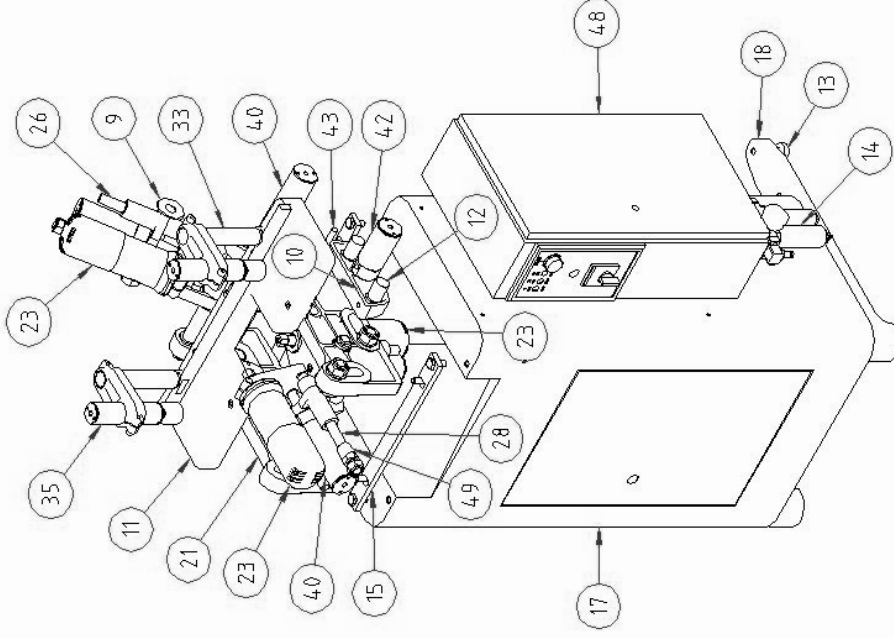

Figure - 1



### 3. SAFETY

#### 3.1. SAFETY INFORMATION

The symbols shown hereunder are necessary to be read with special attention. Not reading or observing of them may cause damage to the equipment or personal injury

**IMPORTANT**

The **IMPORTANT** symbol above is one telling to apply special care and to be careful at carrying out the specified operation.

**CAUTION !**

The **CAUTION!** Symbol above warns you against specific dangers, and requires to read the text. Not observing may cause damage to the equipment.



**DANGER WARNING**

The **DANGER WARNING** above warns you against specific dangers, and definitely requires the text to read. Not observing may result in serious bodily injury.

Please read the user's manual carefully before using the machine or carrying out maintenance.



#### 3.2. PREVENTION OF ACCIDENTS

**3.2.1** Our machines are manufactured in accordance with EN 60204-1 and EN 292-2 CE safety directives, which cover national and international safety directives.

**3.2.2** It is the task of the employer to warn his staff against accident risks, to train them on prevention of accidents, to provide for necessary safety equipment and devices for the operator's safety.

**3.2.3** Before starting to work with the machine, the operator should check the features of the machine, learn all details of the machine's operation.

**3.2.4** The machine should be operated only by staff members, who have read and understood the contents of this manual.

**3.2.5** All directives, recommendations and general safety rules contained in this manual have to be observed fully. The machine cannot be operated in any way for purposes other than those described herein. Otherwise, the manufacturer shall not be deemed responsible for any damages or injuries. And such circumstances would lead to the termination of the warranty.

### 3.3. GENERAL SAFETY INFORMATION



**3.3.1.** The power cable should be led in such a way that nobody can step on it or nothing can be placed on it. Special care has to be taken regarding the inlet and outlet sockets.



**3.3.2.** If the power cable should be damaged during operation, don't touch and unplug it. Never use damaged power cables.

**3.3.3.** Don't overload machines for drilling and cutting. Your machine will operate more safely with power supply in accordance with the stipulated values.



**3.3.4.** Don't place your hands between parts in motion.



**3.3.5.** Use protective eye glasses and ear plugs. Don't wear oversize clothes and jewels. These can be caught by moving parts.



**3.3.6.** Keep your working place always clean, dry and tidy for accident prevention and safe operation.

**3.3.7.** Use correct illumination for the safety of the operator. (ISO 8995-89 The Lighting of Indoor Work Systems)

**3.3.8.** Don't leave anything on the machine.

**3.3.9.** Don't use any materials other than those recommended by the manufacturer for cutting operations on the machine.

**3.3.10.** Ensure that the work piece is clamped appropriately by the machine's clamp or vice.



**3.3.11.** Ensure safe working position, always keep your balance.

**3.3.12.** Keep your machine always clean for safe operation. Follow the instructions at maintenance and replacement of accessories. Check the plug and cable regularly. If damaged, let it replace by a qualified electrician. Keep handles and grips free of any oil and grease.

**3.3.13.** Unplug first, before conducting and maintenance works.

**3.3.14.** Ensure that any keys or adjustment tools have been removed before operating the machine.

**3.3.15.** If you are required to operate the machine outside, use only appropriate extension cables.

**3.3.16.** Repairs should be carried out by qualified technicians only. Otherwise, accidents may occur.

**3.3.17.** Before starting a new operation, check the appropriate function of protective devices and tools, ensure that they work properly. All conditions have to be fulfilled in order to ensure proper operation of your machine. Damaged protective parts and equipment have to be replaced or repaired properly (by the manufacturer or dealer).

**3.3.18.** Don't use machines with improper functioning buttons and switches.

**3.3.19.** Don't keep flammable, combustive liquids and materials next to the machine and electric connections.

#### **4. TRANSPORT OF THE MACHINE**

**IMPORTANT**

\* The transport should be done by qualified personnel only.

- 4.1.** *The machine should be transported by lifting with proper equipment (not touching the ground during the transport).*
- 4.2.** *Machines are covered with nylon for delivery, unless the customer has not required other method of packing.*
- 4.3.** *For the weight and overall dimensions of the machine see Technical Features.*

## **5. INSTALLATION OF THE MACHINE AND ELECTRIC CONNECTION**

### **IMPORTANT**

*Remove the bolts and stoppers for fixing the movable parts of the machine for safe transport before making the electric and pneumatic connections.*

- 5.1** *Place your machine onto an even ground. The machine's overall dimensions are given under Overall Dimensions. The working place should be appropriate for these dimensions.*
- 5.2** *Level the machine by using the adjustment screws on the machine's rear base.*
- 5.3** *Make the air connection with a hose appropriate for the sleeve diameter.*
- 5.4** *Your machine operates under 230 V 50 Hz power supply. Let the electric installation carry out by a qualified electrician.*
- 5.5** *Check the rotation direction of the router bit after making the electric connection.*
- 5.6** *Ensure that the air pressure at the conditioner is 6-8 Bar.*



## **6. MACHINE SAFETY INFORMATION**

*Read the user's manual carefully before starting to operate the machine. Follow the instructions in the manual.*

- 6.1** *The machine has to operated with 230 V 50 Hz. Let the electric installation carry out by a qualified electrician.*
- 6.2** *Lifting, installation, electric maintenance of the machine should be carried out by qualified personnel only.*
- 6.3** *Routine maintenance and scheduled maintenance should be carried out by qualified personnel after unplugging the machine first.*



- 6.4 Ensure that the machine has been cleaned, tested and maintained before starting to operate it.*
- 6.5 Check the safety devices, power cable and moving parts regularly. Don't operate the machine before having replaced defective safety devices or faulty parts.*
- 6.6 Keep foreign materials away from the working area of the machine, keep away from the machine's moving parts.*
- 6.7 Protect the router bit against impacts.*
- 6.8 Don't use the machine for improper purposes (for working of iron and ferrous metals)*

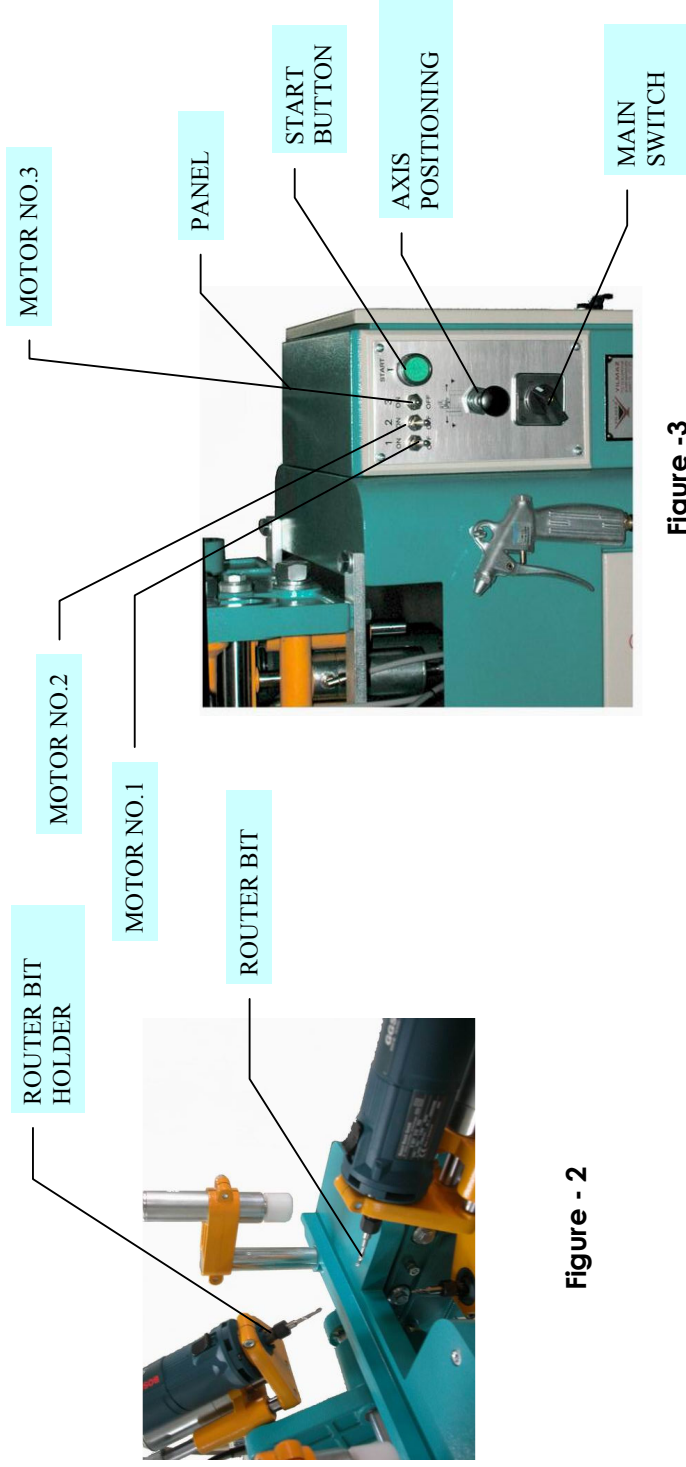

Figure - 2

Figure - 3

## 7. OPERATION

- a. Main Switch ON (Figure-3)
- b. Place the PVC profile, on which you want to open the water slots onto the machine table (Figure-2)
- c. Switch motor No. 1 (Figure-3) to "ON", and press the Start button. At the same time the profile will be clamped automatically and motor No. 1 will start. Then the water slot milling process is carried out automatically.
- d. Apply the same procedure for milling of the other slots.
- e. You can open two slots simultaneously. For this purpose, switch the motors 1-2 or 1-3 to "ON, and press the Start button. The machine will complete the operation automatically.

**NOTE:** The milling depth of the cutter can be adjusted at all three motors. This adjustment can be done with the Motor Adjustment Bolt (Figure-1 No.49).

**NOTE:** The clamps operate pneumatically. The profile is clamped automatically when the Start button is pressed.

- f. The travel speed of the motors can be increased and decreased via the reducers located on the valves inside the panel.
- g. The table travel speed can be adjusted via the reducer located on the table motion piston.

### 7.1. CHANGING THE ROUTER BIT

**IMPORTANT**

If it becomes necessary to replace the router bit for any reason unplug the machine first.

**7.1.1** Hold the router bit holder with a 17 mm wrench key (FIGURE 12).

**7.1.2** Place the cylindrical pin delivered with the wrench key into the hole on the router bit holder, and turn the key to the left.

**7.1.3** Replace the router bit holding unit. Apply reverse order to tighten the router bit.

**7.1.4** Check the router bit before using it. The router bit has to be inserted into the holder properly. Don't use damaged router bits with improper function. Operate the machine for at least 30 seconds to be sure that the router bit has been inserted and fixed correctly.

## 7.2. ADJUSTING THE AIR PRESSURE ON THE MACHINE

The air supply to the machine has to balance 6-8 Bar pressure. Don't operate the machine at an air pressure lower than 6 Bar. Read the manometer on the conditioner to adjust and to check the air pressure (See Figure 2). Pull the conditioner adjustment switch up.

**7.2.1** Turning the adjustment button in clockwise direction increases the pressure, turning it in counter clockwise direction decreases the pressure

**7.2.2** Once you read 6-8 Bar on the manometer, push the adjustment button of the conditioner down and lock it in that position.

**7.2.3** In order to prevent that the water inside the air system causes damage to the pneumatic system components, the conditioner unit collects the water in the collection receptacle. Discharge the collected water periodically (at the end of the working day) by pressing the button under the cylinder depot of the conditioner.

**7.2.4** The manufacturer recommends to use the following oils with the conditioner: TELLUS C 10 / BP ENERGOL HLP 10/ MOBIL DTE LIGHT / PETROL OFISI SPINDURA 10.

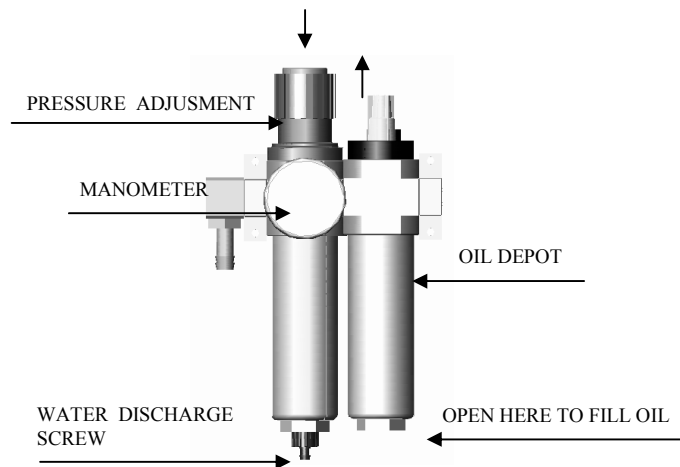

Illustration-2

## 8. MAINTENANCE

### 8.1. PERIODIC CHECKS

**8.1.1** Ensure that the working table and all parts are clean and dry. Degrease the table.

**8.1.2** Remove all kinds of burr, chip and foreign materials form the machine surface.

**8.1.3** Check the air pressure.

**8.1.4** Check the air pressure filters and the oil level in the conditioner. Fill up if the oil level is low. (ILLUSTRATION 2)

## **8.2 MAINTENANCE AT THE END OF THE WORKING DAY**

**8.2.1** Disconnect the power and air supply.

**8.2.2** Remove all kinds of burr, chip and foreign materials from the machine surface.

**8.2.3** Clean the table and dry it with a piece of cloth (don't use any materials which could cause damage to the machine's paint).



**Disconnect the power and air supply before carrying out all these works.**

## **9. TROUBLESHOOTING GUIDE**

Here are some recommendations for solving urgent problems. If the trouble cannot be solved, or if you have a problem other than those described hereunder, please contact our technical service or your nearest dealer.

**9.1.** Check the socket whether power supply is established.

**9.2.** Tighten the router bits at the cylindrical shaft side.

**9.3.** Use router bits with a shaft diameter in accordance with that of the router bit holders.

**9.4.** Keep the factory settings for motor travel speed and table travel speed. Excessive travel speed may cause the router bits to brake.

**9.5.** Keep the router bit of motor No. 2 away from the table when adjusting the profile cutting depth.

**9.6.** Don't use broken and damaged router bits, replace them with new ones.



## 10. ELECTRIC / PNEUMATIC COMPONENTS

### 10.1 ELECTRIC COMPONENTS

### 10.2 PNEUMATIC COMPONENTS

item/m

item/m

item/m

161-008	PAKO SWITCH CA10 A202	1	241-004	6 MM AIR HOSE	1
161-010	MA-111 LATCH SWITCH ON-OFF	3	241-005	AIR GUN HOSE	5
163-003	BOSCH MOTOR	3	241-009	FRC-1/8-D-MINI CONDITIONER	1
164-015	PRINTED PLUG 3*1	1	241-012	SV 1/4-5/2 D.O VALVE	1
165-011	PERFORATED RAIL (KLEMSAN)	0.25	241-013	MFH 5-1/8 230V VALVE (WATER DISCHARGE)	4
165-012	WGDI CONNECTOR STOPPER	3	241-014	1/8 EXHAUST REDUCER (SINTER)	6
165-016	CABLE CHANNEL (37.5*37.5)	0.5	241-016	1/8 EXHAUST (SC-SINTER)	2
165-020	PEK 2.5 MM BEIGE CONNECTOR	10	241-020	MVH-3-1.7-QS-4/SELENOID VALVE	1
165-025	PEK 2.5 MM BLUE CONNECTOR	5	241-021	1/4 EXHAUST REDUCER (SVE-SINTER)	2
165-028	TERMINAL PLATE NPP 2.5 10	5	241-028	MSSD-V/ SOCKET	1
165-031	PG 13.5 SLEEVE	1	242-001	AIR GUN LBP-1/4	1
165-035	PG 36 SLEEVE	1	243-004	1/4 HOSE INLET	1
165-040	WARNING LABEL P 2S	2	243-008	1/4 TRIPLE DISTRIBUTOR	1
165-046	START BUTTON	1	243-010	1/4-1/8 NIPPEL (DECREASING)	1
165-024	UK 2.5/2 CONNECTOR	4	243-012	1/4-6 ANKLE (S6520-6-1/4)	4
165-023	UK 2.5/4 CONNECTOR	1	243-014	1/4-8 SLEEVE (S6510-8-1/4)	1
165-045	NO:2 PANEL SPIRAL (THICK)	1	243-023	1/8-6 ANKLE (S6520-6-1/8)	8
165-060	CABLE SHOE SKN 1-0.4	3	243-024	MID THREADED T (S6430-6-1/8)	1
165-067	NO:1 PANEL SPIRAL (THIN)	0.25	243-025	1/8-6 SLEEVE (S6510-6-1/8)	11
165-078	NO:1 CONNECTOR NUMBER	2	243-038	SEXTANT Y (6560-6)	2
165-079	NO:2 CONNECTOR NUMBER	2	243-045	SCU-604-1/8 SCREW TYPE REDUCER	1
165-080	NO:3 CONNECTOR NUMBER	3	243-046	MCU-704-6-1/8 MANUAL REDUCER	1
165-081	NO:4 CONNECTOR NUMBER	4	244-005	O RING 34*2	10
165-082	NO:5 CONNECTOR NUMBER	8	244-011	O RING 28*2	2
165-083	NO:6 CONNECTOR NUMBER	4			
165-084	NO:7 CONNECTOR NUMBER	4			
165-085	NO:8 CONNECTOR NUMBER	4			
165-086	NO:9 CONNECTOR NUMBER	2			